

**CALAVERAS COUNTY
WATER DISTRICT**

INSTALLATION

of

GRAVITY SEWER SERVICE

INSTALLATION OF GRAVITY SEWER SERVICE

GENERAL

The following information is intended to assist the contractor or homeowner in the installation of the building sewer service line by gravity flow. The building sewer service line is that portion of the line from two (2) feet outside the building to the property line cleanout. Work performed on private property may be performed by the owner provided that all materials and methods are in accordance with these Standards, the Standard Drawings, and the Uniform Plumbing Code.

No roof gutters, surface or subsurface drains, or other such appurtenances shall be connected to the building sewer.

INSPECTION

The District shall inspect the installation of the service. The District requires a minimum of 48-hours notice prior to the start of construction. The District inspector will meet and coordinate with homeowner/contractor to discuss the requirements of the District and the location of the service(s) as submitted with the Application.

When an inspection is scheduled but the work is not complete and/or not acceptable, a re-inspection fee will be charged.

Trenches shall be kept open until the piping has passed inspection.

INSTALLATION

- A. Pipe Material. See Approved Material List.
- B. Location. The owner is responsible for verification, prior to construction, that the property line cleanout is located on the parcel to be served. No building sewer shall be installed under any building or structure such as patios, stairs, carports, pools, driveways, or other such appurtenances. No building sewer shall be laid parallel within five (5) feet of a retaining wall foundation. Sewers are to be 50 feet from water wells and streams.
- C. Excavations. All excavations shall be open trench and be inspected by the District. The trench section shall be in accordance with the Standard Drawing provided herein. Building services that are parallel to and deeper than the footing of a building or structure shall be laid at least 45-degrees therefrom with a minimum of two (2) foot clearance.
- D. Common Trench. Water and sewer service may be installed in the same trench if a solid shelf to one side of the common trench is provided for the water service such that the water service will have a clearance of 12-inches from the sewer in

the horizontal and vertical directions (see water service detail). Water services shall always cross 12-inches above a sewer or drain pipe. Electrical service is prohibited in the same trench as the water and sewer. The water and/or sewer trench have 12-inches of separation from other utilities.

- E. Minimum Sewer Slope. Sewers are to be laid at a minimum slope of two percent (2%), one-quarter inch ($\frac{1}{4}$ ") per foot.
- F. Minimum Cover. The minimum cover shall be eighteen (18) inches from top of pipe to finish surface.
- G. Alignment. The building sewer is to be laid at a uniform grade and in a straight alignment. Changes in direction will be made only with the proper fittings as approved by the inspector.
- H. Cleanouts. A building cleanout is required within two (2) feet of the structure. Cleanouts shall be installed a maximum of every one hundred (100) feet along the building sewer and at changes in direction as directed by the inspector.
- I. Utility Crossings. Building sewers are to cross under water pipes by a minimum of twelve (12) inches. A minimum vertical clearance of twelve (12) inches is required for all other utilities.
- J. Pipe Bedding. See Approved Material List. Bedding material shall be placed two (2) inches below and six (6) inches above the pipe.
- K. Backfill Material. Native material may be used provided it is free from organic debris and rock. Prior to backfilling over a building sewer, all construction shall be inspected and approved by the District inspector. Any building sewer backfilled prior to inspection approval shall be required to be re-excavated for proper inspection and approval.
- L. Tracer Wire. Building service is to have tracer wire along the entire length from the cleanout to the building cleanout.
- M. Testing. Air or water test is required for building sewers by plugging the sewer at the building and at the point of connection at the property line cleanout.
- N. Relief Valve. A sewer popper valve shall be incorporated with the building cleanout as specified by the standard drawings.

END

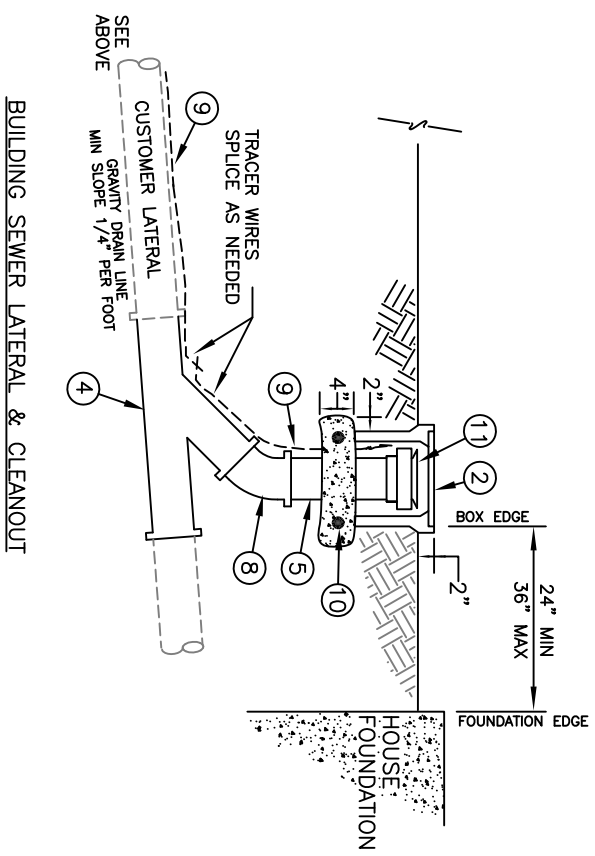
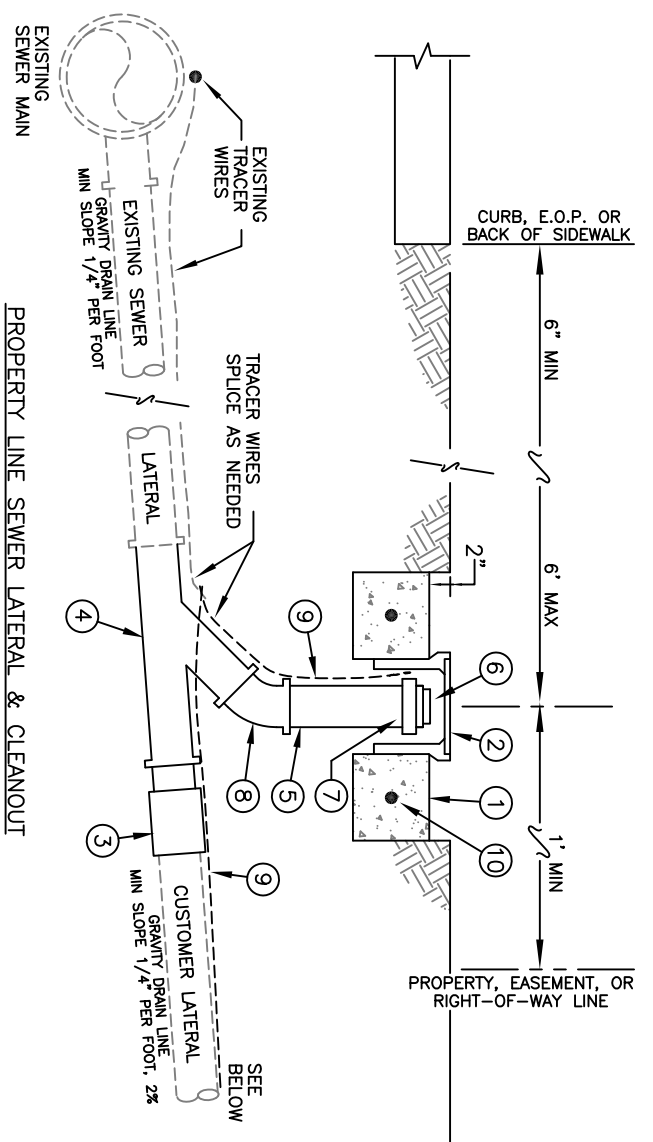

ITEM#	DESCRIPTION
1	18"x18"x6" CONCRETE PAD
2	CLEANOUT BOX
3	REMOVE 4" EXPANSION PLUG AND INSTALL RIGID PVC COUPLING; CUSTOMER LINE SIZED PER UPC.
4	4" WYE (MIN), PVC
5	4" PVC
6	THREADED PLUG, PVC
7	SLIP COUPLING W/THREADED FITTING, PVC
8	LONG-RADIUS SWEEP, PVC
9	TRACER WIRE
10	#4 REBAR REINFORCEMENT
11	SEWER POPPER

NOTES:

1. AN APPROVED BUILDING PERMIT FOR THE PARCEL REQUESTING SERVICE IS REQUIRED AT THE TIME APPLICATION FOR WATER AND/OR SEWER SERVICE IS MADE.
2. SEWER CLEANOUTS SHALL BE INSTALLED AT PROPERTY LINE, BUILDING FOUNDATION, AT 90° OR GREATER TURNS AND FOR EVERY 100' OF LINE.
3. CUSTOMER REQUESTING SERVICE SHALL BE RESPONSIBLE FOR INSTALLING CLEANOUT AT PROPERTY LINE, AT THEIR EXPENSE, IF ONE IS NOT PROVIDED.
4. SEWER SERVICE, FROM PROPERTY LINE TO BUILDING, SHALL BE INSPECTED, OPEN-TRENCH, BY CCWD. AFTER HOOK-UP IS MADE, SCHEDULE INSPECTION WITH CCWD. ALLOW A MINIMUM OF 48 HRS FOR INSPECTION TO OCCUR.

CALAVERAS COUNTY WATER DISTRICT

**CUSTOMER SERVICE DETAILS
GRAVITY SEWER SERVICE**

DRAWN BY: CCWD STAFF	SCALE: NONE	CCWD STANDARD DRAWING NO.
APPROVED: S.HUTCHINGS	DATE: 1/12/2008	SERVICE CONNECTION SEWER HANDOUT 1